

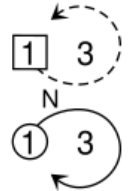

JOIE DE VIVRE (J8x32) 3C (4C set)

Irene van Maarseveen RSCDS Bk 39

- 1- 8 1s set, cast 1 place, 1s dance down between 3s & cast back to 2nd place on own sides
- 9-16 2s+1s+3s turn RH & chase 1/2 way round clockwise
- 17-24 3s+1s+2s dance DoSiDo, set & 1/2 turn partners RH for Allemande
- 25-32 3s+1s+2s dance Allemande





JOIE DE VIVRE				8x32 J		
S 		2 1 3 T_R	2 1 3 	3x 1x 2x D	3x 1x 2x S T_R^{1/2}	3 1 2 A

Irene van Maarseveen, 1996, RSCDS Book 39.2, RSCDS Thirty Popular Dances Vol 2

3C/4C longwise set.

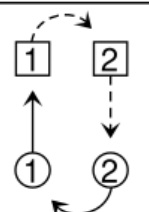
PLEASURE IS MINE (S8x32) 2C (4C set)

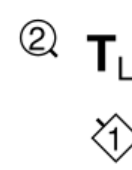
- 1- 8 1s+2s dance Diamond Poussette
- 9-12 1L+2M set & cast 1 place (L down, M up) **as** 1M+2L stand & cross to prttrs place
- 13-16 1M+2L set & cast 1 pl (L up, M dn) **as** 1L+2M stand & cross to prttrs pl. (2)(1)
- 17-24 1M+2L turn RH 1.1/2 times, 1L+2M turn LH 1.1/2 times
- 25-32 1s+2s dance Tournee:-
 - 25-28 1s+2s dance into prom hold (Men with partner on right, 1s face Men's side & 2s face Ladies side), both couples wheel anticlockwise 1/2 way & Men turn Ladies into middle
 - 29-32 Both couples turn 1.1/2 times (2s RH, 1s LH) & dance out to places

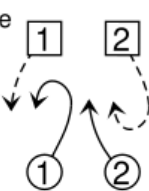
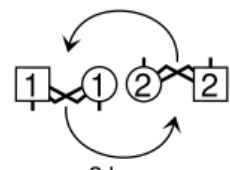
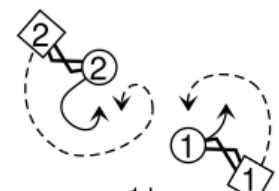
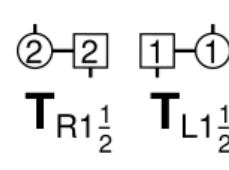
THE PLEASURE IS MINE				8x32 S		
1 2 P						
Tournée 						
	2 bars	1 bar				

Roy Goldring, Graded and Social Dances 3

2C/4C longwise set.

CROM ALLT (The Crooked Burn) (R8x32) 3C (4C set)

Roy Goldring 24 G & S Dances

- 1- 8 1s dance reels of 3 on own sides (in & down to start)
- 9-16 1s+2s turn on sides 1.1/2 times (Men RH & Ladies LH), 1s dance between 3s & cast up to 2nd place on own sides
- 17-24 1s+1st corners Adv+Ret, 1s+1st corners turn RH
- 25-32 1s+2nd corners Adv+Ret, 1s+2nd corners turn LH

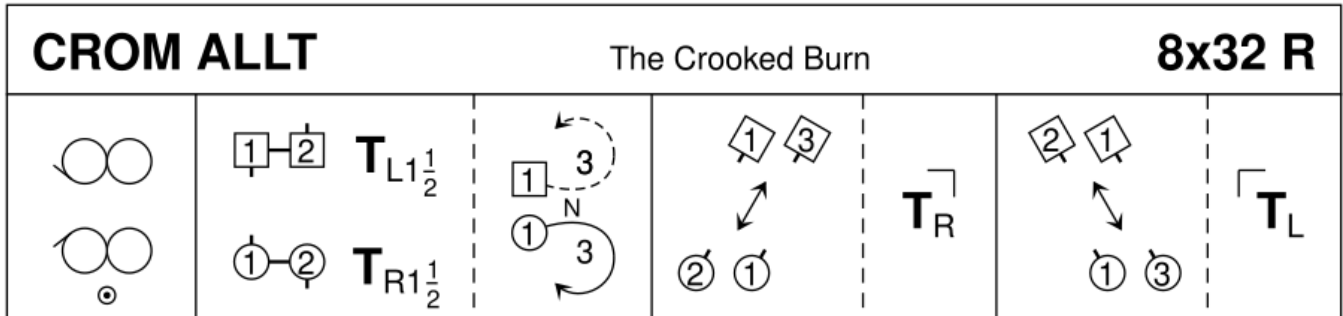

Roy Goldring, 24 Graded and Social Dances, RSCDS Graded Book 3.4

3C/4C longwise set.

THE COMPLEAT GARDENER (J8x32) 3C (4C set)

Irene Paterson RSCDS Graded Bk 3

- 1- 8 1s+2s Dance Set & Rotate:-
 ` Set, rotate singly & dance on 1 place clockwise, change places RH on sides & dance on 1 place to own sides (1s in 2nd pl)
- 9-16 1s cross RH & cast right, cross LH up/down & cast left to end facing 1st corners
- 17-24 1s dance Pass+Turn with 1st corners & pass RSh to face 2nd corners, dance Pass+Turn with 2nd corners & pass RSh to 2nd place own sides
- 25-32 2s+1s+3s circle 6H round & back

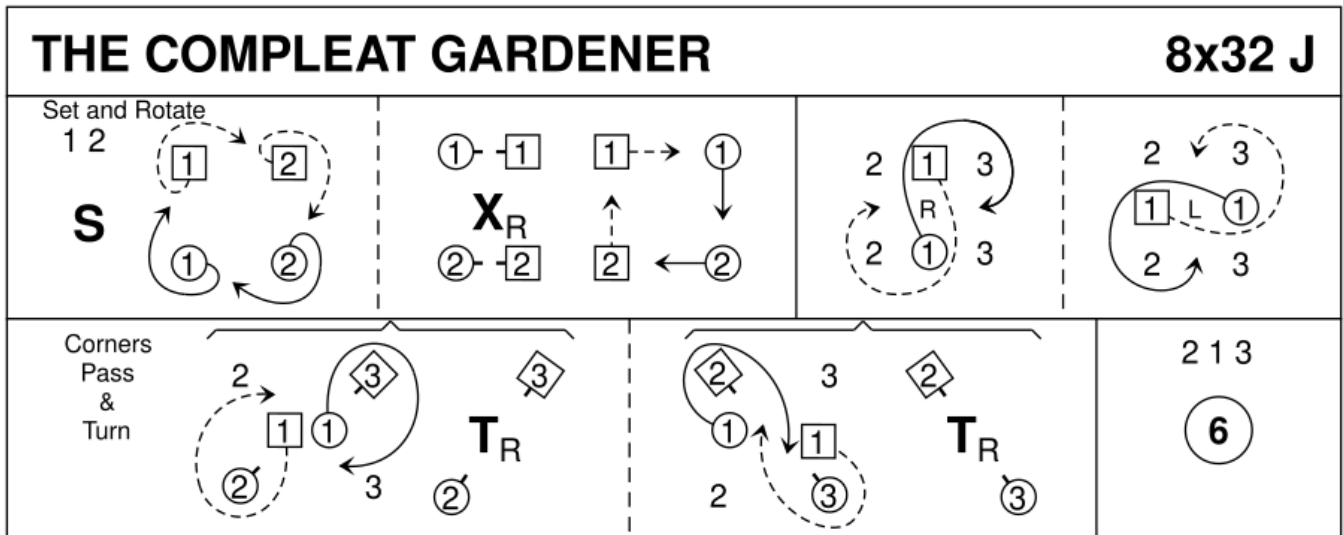

Irene Paterson, RSCDS Graded Book 3.14

3C/4C longwise set.

MACDONALD OF THE ISLES (S3x32) 3C Set

Derek Haynes Carnforth Coll 2

- 1- 8 2s dance full diagonal Reels of 4 with 1st corners, passing by the LSh to face 2nd corners
- 9-16 2s dance full diagonal Reel of 4 with 2nd corners to end in original places
- 17-24 All dance Snowball Grand Chain for 3 cples to end 3 (2) 1:
 - `1s cross RH & change places LH on side with 2s
 - `1s change places RH with 3s **while** 2s cross over RH
 - `1s cross LH **while** 2s & 3s change places LH. 3 (2) 1
- 25-32 3s+2s (top 2 couples) dance 1/2 R&L, 3s dance 1/2 Fig of 8 round end couples (3M up & 3L down) to end in 2nd place own side 2 3 1

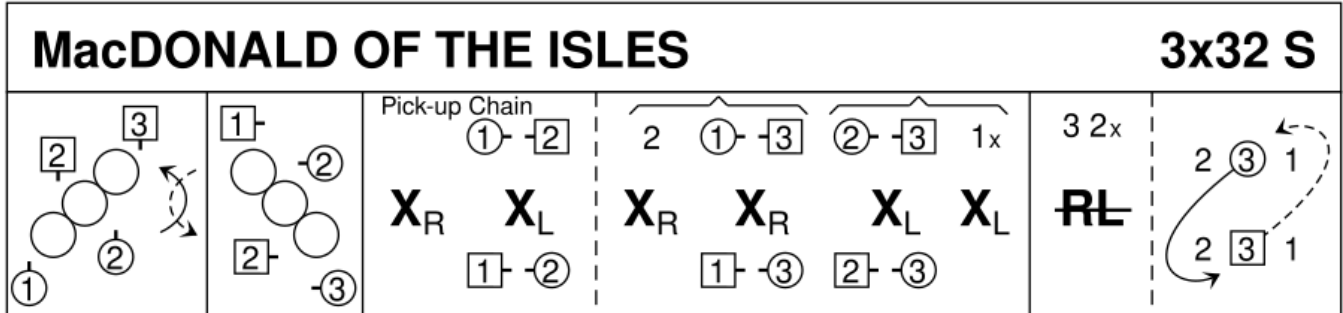

Derek Haynes, 1966, Carnforth Collection 2, RSCDS Thirty Popular Dances Vol 2

3C/3C longwise set.

DA RAIN DANCIN' (R8x32) 3C (4C set)

Ron Wallace Whiteadder Coll

- 1- 8 1s dance down below 3s, cast up round 3s to 2nd place own side, 2s+1s+3s set & cross RH
- 9-16 1s dance up round 2s & cast down to 2nd place opposite sides, 2s+1s+3s set, 1s turn LH to face 1st corners **while** 2s & 3s cross LH
- 17-24 1s set to corner (1), set to partner (1) & turn 3/4 RH (2 bars) to face 2nd corner; 1s set to corner (1), set to partner (1) & turn 3/4 RH (2 bars) to 2nd place own side
- 25-32 2s+1s+3s circle 6H round & back

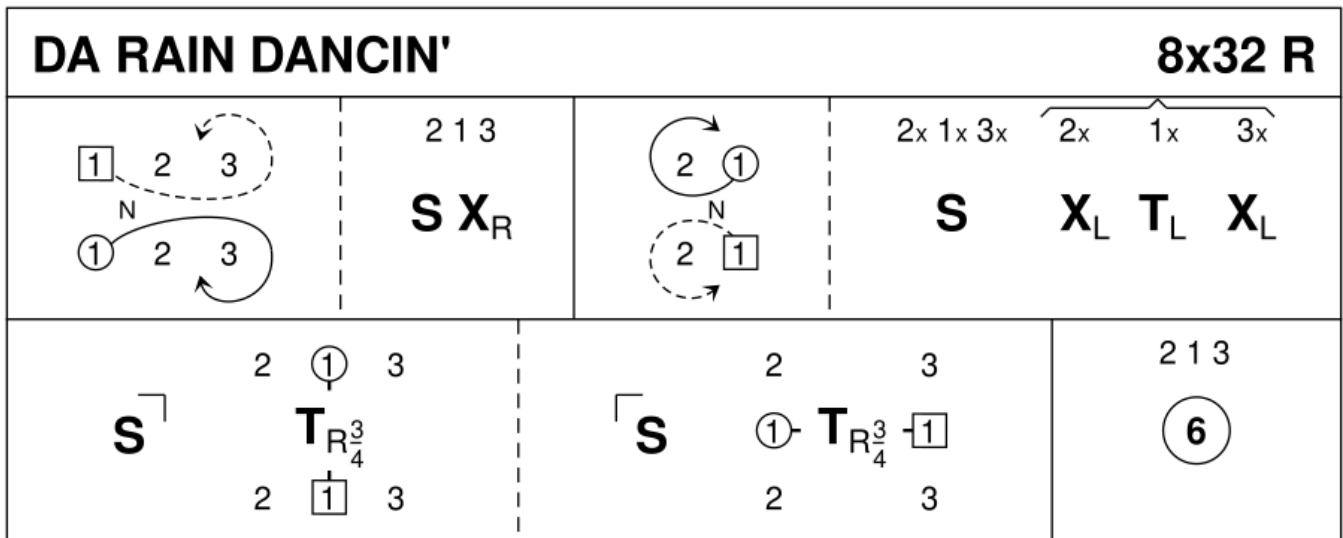

Ron Wallace, 1991, Whiteadder Collection, RSCDS Thirty Popular Dances Vol 2

3C/4C longwise set.

THE LUCKENBOOTH BROOCH (J8x32) 3C (4C set) John Bowie Dickson Glendarroch Sh 28 & RSCDS Bk 5

- 1- 8 1s in prom hold (Lady on Man's left) dance reel of 3 with 2s (RSh to 2M) & end facing 3M
- 9-16 1s dance reel with 3s (RSh to 3M) ending with 1s dancing into centre facing Men's side
- 17-24 1M casts up & 1L dn into centre & dance out Ladies' side, 1M cast up & 1L dn to end 1M b'tw'n 2s facing dn & 1L+3s face up as 2s+3s dance R&L
- 25-32 2s+1s+3s set twice, 1s turn RH 1.3/4 times to 2nd places

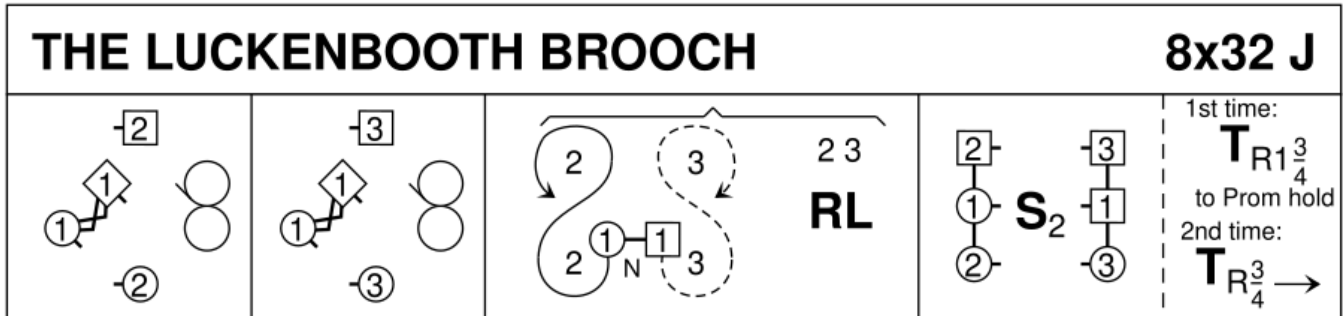

John Bowie Dickson, 1968, RSCDS Book 53, Glendarroch Sheet 28

3C/4C longwise set.

12 COATES CRESCENT (S4x32) 4C set

RSCDS Bk 40

- 1- 8 All set on sides & cross RH, all set & cross back RH
- 9-16 1s dance down to meet 4s who dance up & 1L+4L also 1M+4M dance out own sides, cast back to places & 1s lead down to 4th place (2s+3s+4s step up 15-16)
- 17-24 3s+4s (middle couples) dance R&L
- 25-32 2s+3s also 4s+1s dance RH across & LH back

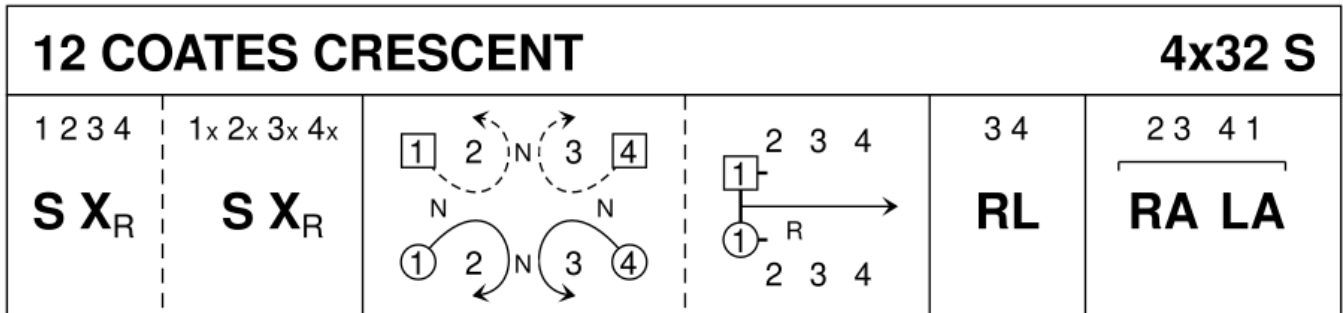

RSCDS, 1998, RSCDS Book 40.5

4C/4C longwise set.

SHIFTIN' BOBBINS (R8x32) 3C (4C set)

Roy Clowes Ormskirk 6

- 1- 8 1s cross RH to double triangle position with 2s+3s & set, 1s cast up to top & dance down until they are between 2s & 3s
- 9-16 1L dances RH across with 2M+3M **while** 1M dances LH across with 2L+3L, 1s followed by 2s+3s dance down centre
- 17-24 3s followed by 2s+1s dance up & 3s+2s cast down to places, 1L dances LH across with 2M+3M **while** 1M dances RH across with 2L+3L
- 25-32 1s dance up to top & cast down to 2nd place opposite side, 1s dance 1/2 Fig of 8 around 2s to end in 2nd place on own sides

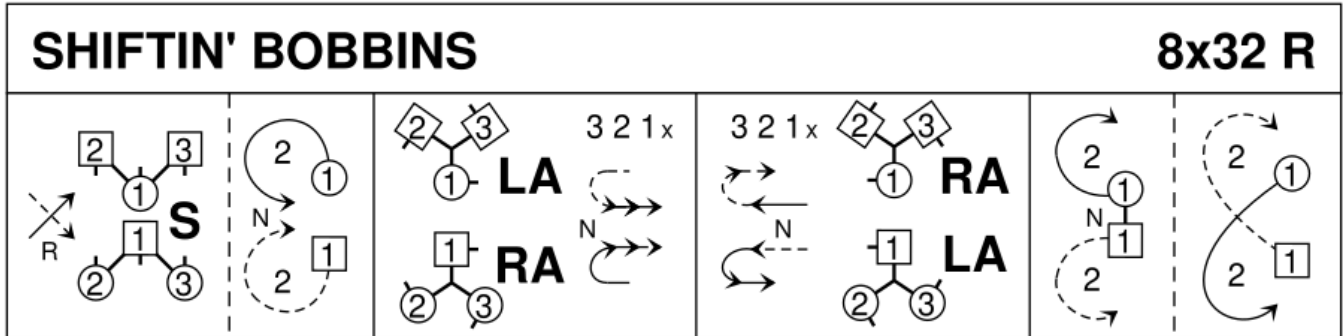

Roy Clowes, Ormskirk Book 6, RSCDS Thirty Popular Dances Vol 2

3C/4C longwise set.

Intermission

PELORUS JACK (J8x32) 3C (4C set)

Barry Skelton RSCDS Bk 41

- 1- 8 1s cross RH & cast 1 place (2s step up 3-4), 1s dance RH across with 3s. 1s end with Man facing his 1st corner with his partner behind him
- 9-16 1s dance Alternating Tandem 1/2 reel of 3 with 1st corners to face Man's 2nd corner, 1s dance Alternating Tandem 1/2 reel of 3 with 2nd corners
- 17-24 1s dance Alternating Tandem 1/2 reels of 3 with Ladies' 1st corner (pstrn), 1s dance Alternating Tandem 1/2 reel with Ladies' 2nd corner (pstrn)
- 25-32 1M followed by partner dance into LH across with 2s, 1s retain LH & 1/2 turn to own sides & 2s+1s+3s set

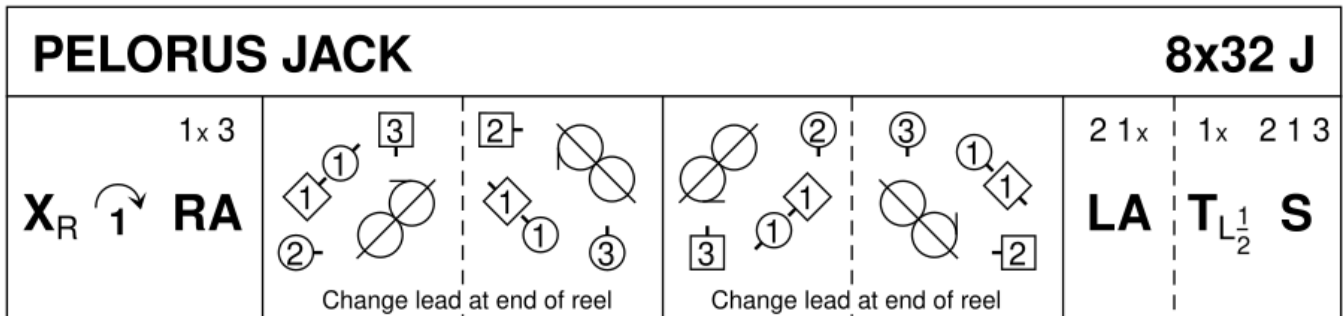

Barry Skelton, 1993, Dolphin Book, RSCDS Book 41.1, RSCDS Thirty Popular Dances Vol 2

3C/4C longwise set.

MISS GIBSON'S STRATHSPEY (S8x32) 3C (4C set)

Derek Haynes RSCDS Leaflet Dances 18

- 1- 8 1s+2s set, turn partners 2H opening out into 4H round
- 9-16 1s+2s dance the Knot, 1s turn LH to end facing 1st corners
- 17-24 1s turn 1st corners RH, partner LH, 2nd corners RH & partner 3/ 4 LH finishing in middle facing opp sides ready for ...
- 25-32 1s dance RH across, (1M with 3s & 1L with 2s), pass partner RSh & dance LH across with other couple, 1s end in 2nd place

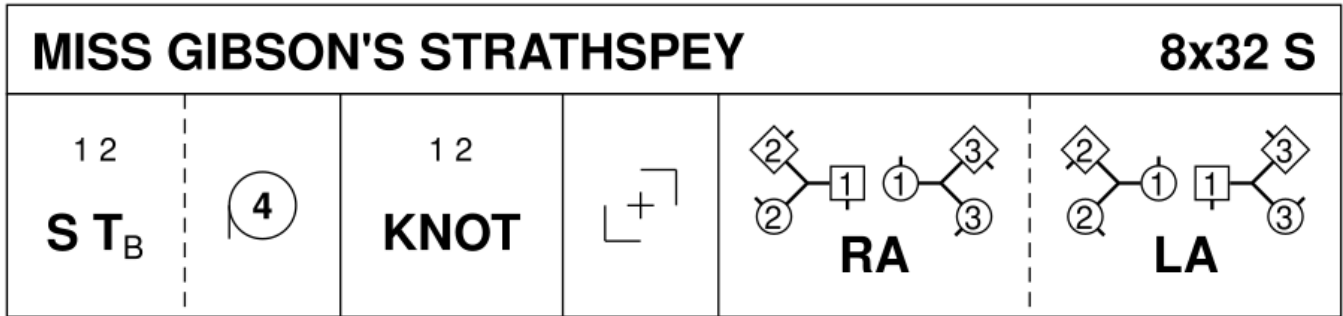

Derek Haynes, 1979, RSCDS Leaflet 10

3C/4C longwise set.

TRIP TO TIMBER RIDGE (R8x32) 3C (4C set) Linda Henderson Heart of San Francisco & RSCDS Bk 52

- 1- 8 1s turn RH, cast (2s step up) then 1L+2s & 1M+3s dance RH across. 1s end facing 1st corners
- 9-16 1s dance Corner Pass+Turn with 1st corners, pass RSh & repeat with 2nd corners. 1s pull back RSh to end BtoB in centre facing opp sides
- 17-24 2s+1s+3s dance Double Triangles. Bars 23-24 1s petronella turn to 2nd place own sides
- 25-32 2s+1s+3s circle 6H round and back

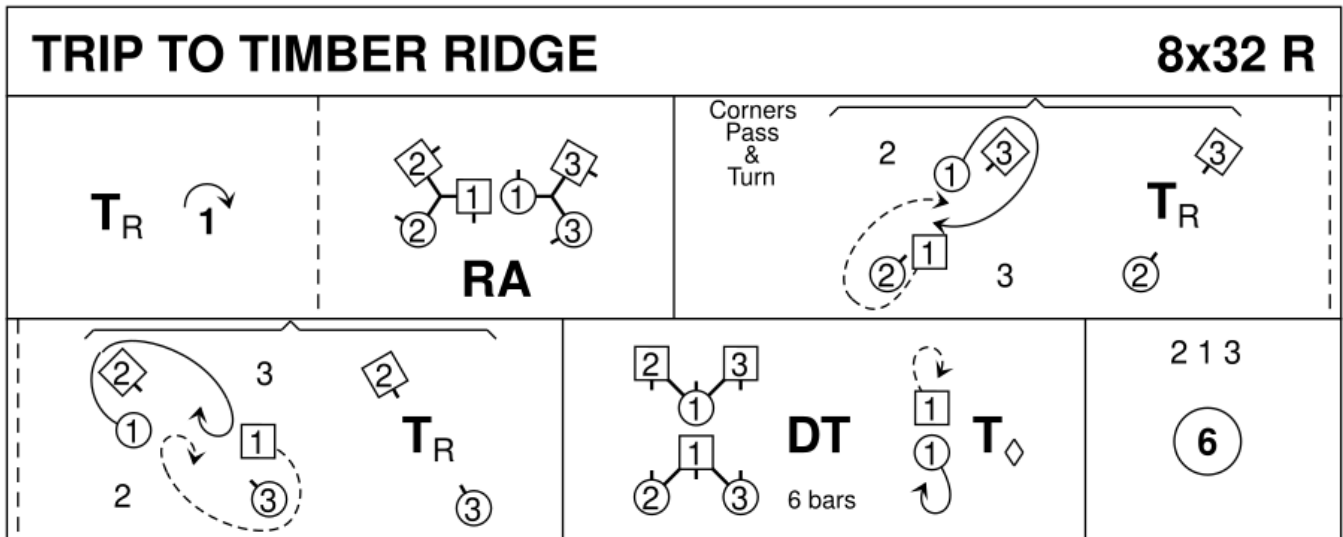

Linda Henderson, 2010, RSCDS Book 52.12

3C/4C longwise set.

FLOWERS OF EDINBURGH (R8x32) 3C (4C set)

RSCDS Bk 1

- 1- 8 1L followed by partner casts below 3s, 1L crosses & dances up behind Men as 1M dances up centre to 1st places on opposite side & 1s set
- 9-16 1M followed by partner repeat above Fig & set in own places
- 17-24 1s lead down the middle & back
- 25-32 1s+2s dance Poussette. 2 1 3

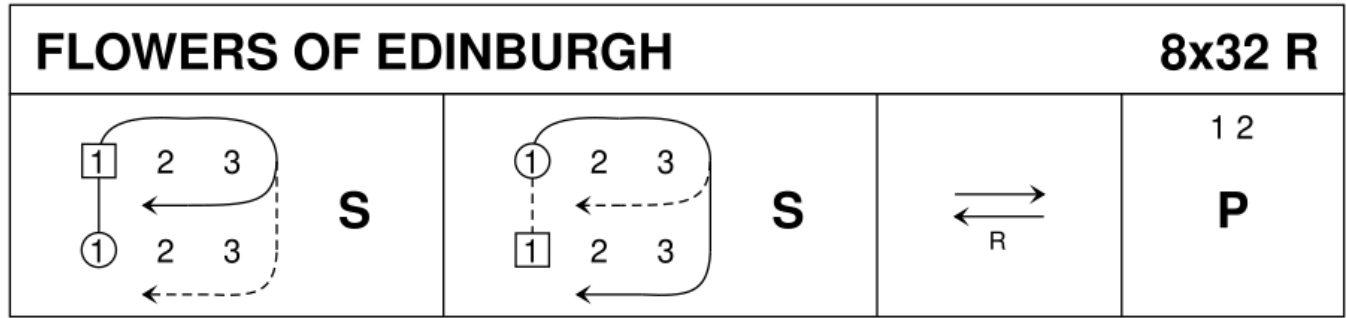

Hughes, 1867, RSCDS Book 1.6

3C/4C longwise set.

THE ROBERTSON RANT (S80) Sq.Set

Mrs Douglas Winchester RSCDS Bk 39

- 1- 8 All circle 8H round & back
- 9-16 All Ladies dance RH across 1/2 way & turn opposite Man LH, all Ladies dance 1/2 RH across & turn partner LH
- 17-24 1s+3s dance reel of 4 (Ladies start by passing LSh as Men set)
- 25-32 All set (HS) to corners, turn 2H twice
- 33-40 2s+4s dance reel of 4 (Ladies start by passing LSh as Men set)
- 41-48 All set (HS) to corners, turn 2H twice
- 49-56 All Ladies circle left to face partners (Ladies BtoB), set to & turn partners 2H
- 57-64 All Men circle right to face partners (Men BtoB), set to & turn partners 2H
- 65-72 All dance Grand Chain
- 73-80 All take allemande hold & dance anticlockwise once round set, bringing Ladies into centre for bow/curtsey

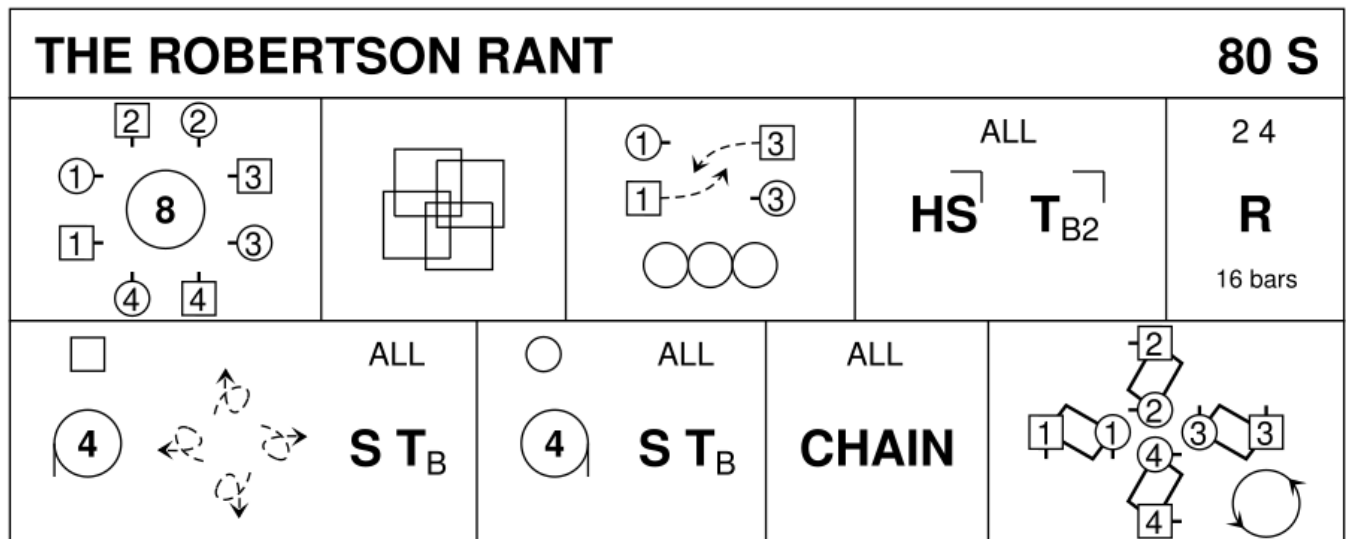

Mrs Douglas Winchester, 1949, RSCDS Book 39.8

4C/4C square set.

MRS STEWART'S JIG (J8x32) 3C (4C set)

Frans Ligtmans RSCDS Bk 35

- 1- 8 1s set, 1L followed by partner casts 2 places, 1L crosses (below 3s) & casts up on Men's side to 2nd place facing down **while** 1M dances round 3L & up the middle to 2nd place Ladies' side facing down
- 9-16 2s+1s+3s dance Grand Chain, end with 2M & 1M facing out
- 17-24 2s+1s dance Ladies' Chain
- 25-32 2s+1s+3s Adv+Ret; 1s turn 1.1/2 RH to own sides. 213

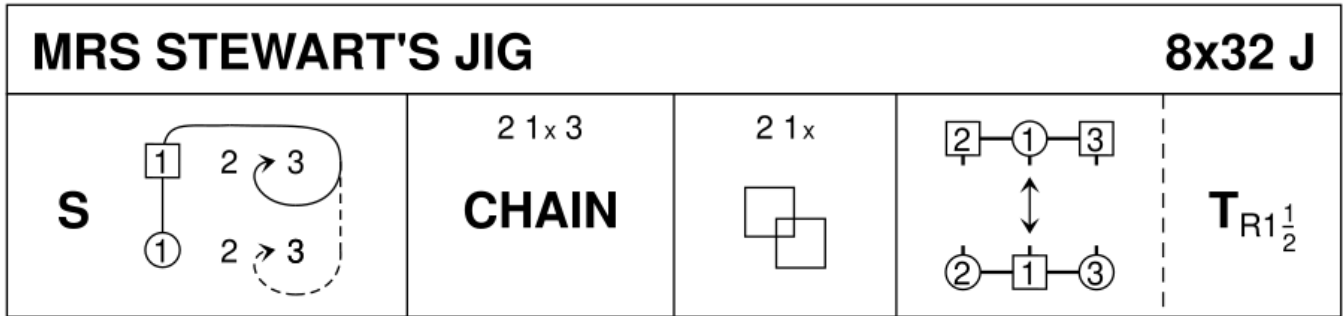

Frans Ligtmans, 1986, RSCDS Book 35.1

3C/4C longwise set.

THE REEL OF THE ROYAL SCOTS (R8x32) 3C (4C set)

Roy Goldring RSCDS Leaflet Dances 27

- 1- 4 1s 1/2 turn 2s on sides (1M RH - 1L LH) to 1s in centre BtoB facing out, 2s+1s+3s set,
- 5- 8 1s 1/2 turn 3s on sides (1M LH - 1L RH) to 3s in centre BtoB facing out & 2s+3s+1s set
- 9-16 1s followed by 3s dance up between 2s, cast down 1 place; 1s dance down between 3s & cast up to 2nd place, 3s loop into 3rd place
- 17-24 1s turn 1st corners RH, pass partner RSh turn 2nd corners RH & cross passing partner RSh to 2nd place own sides
- 25-32 2s+1s+3s circle 6H round & back

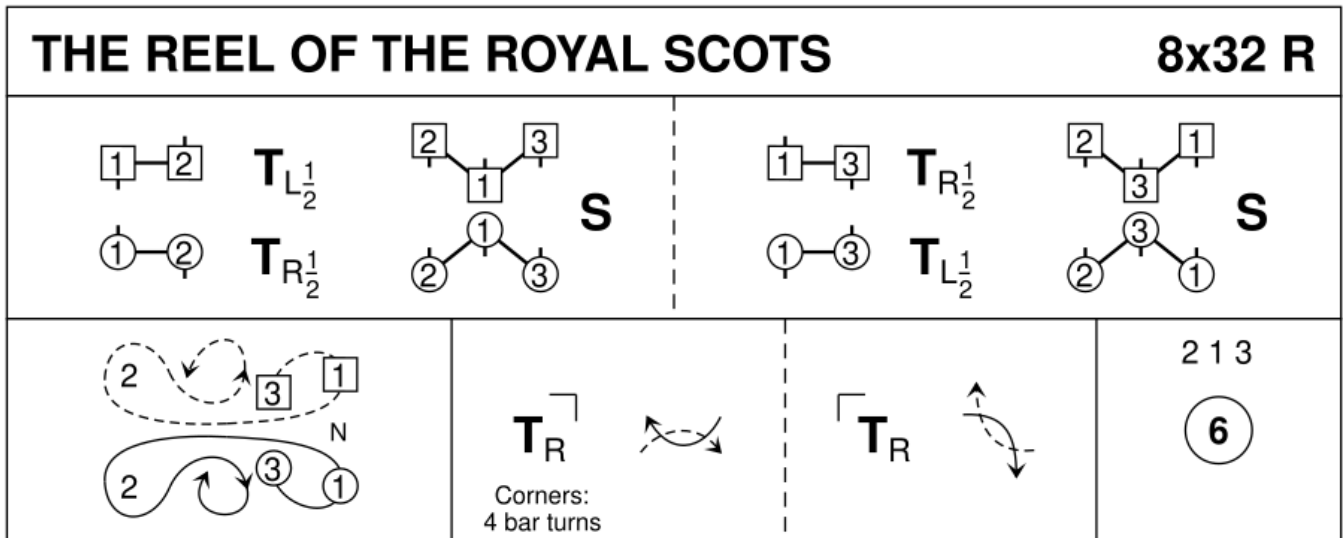

Roy Goldring, 1983, RSCDS Leaflet 7

3C/4C longwise set.