

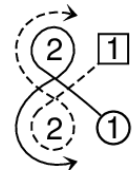

November 2017 Portland Dance Cheat Sheets and Diagrams

LADY CATHERINE BRUCE'S REEL (J8x32) 2C (4C set)

Book of Graded SCDs

- 1- 8 1s lead down the middle and up
 9-16 1s+2s dance Allemande
 17-24 1s dance full Fig of 8 round 2s
 25-32 2s+1s circle 4H round and back

LADY CATHERINE BRUCE'S REEL			8x32 J
	1 2 A		2 1 



RSCDS Graded Book 1.7

2C/4C longwise set.

BARBARA'S STRATHSPEY (S8x32) 3C (4C set)

Sue McKinnell RSCDS Book 46

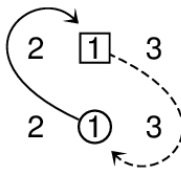
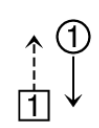
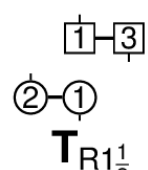
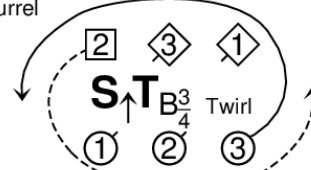
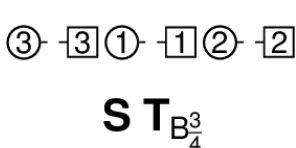
- 1- 8 1s set and cast 1 place (2s step up) and dance ½ Fig of 8 (1M round 2s, 1L round 3s)
 9-16 2s+1s+3s set and 1s cross passing RSh; 2M+1M also 1L+3L turn RH 1½ on sides
 17-24 1s+2s+3s dance 3 couple Bourrel:
 1M+3L also 2M+1L set advancing and ¾ turn 2H to line up/down middle then ½ turn single to face own partners as 3M and 2L chase CCW to face them; all set and turn 2H to own sides to end in order 3, 1, 2
 25-32 All chase CW halfway round; all ½ turn and twirl partners RH

BARBARA'S STRATHSPEY			8x32 S
S 		2 1 x 3 S 	 T_R1½
Bourrel  S T_B³₄ Twirl	 S T_B³₄	3 1 2  Chase	2x 1x 3x T_R¹₂ & Twirl

Sue McKinnell, 2006, suedan.com, RSCDS Book 46.4

3C/4C longwise set.

DOS EQUIS (R4x32) 4C square set

Sue McKinnell Leaflet

- 1- 8 Women dance RHX to end facing between partners and corners, all join hands (RH to partner/LH to corner) and set as in double triangles; all turn partners RH
 9-16 Men dance LHX to end facing between partners and corners, all join hands (LH to partner/RH to corner) and set as in double triangles; all turn partners LH
 17-24 1s+3C dance ladies' chain
 25-32 All dance into center, pull back LS and dance out (2 bars); all chase CCW 1 place (2 bars) and turn partners LH (4 bars) to end 2, 3, 4, 1

November 2017 Portland Dance Cheat Sheets and Diagrams

EQUILIBRIUM (J8x32) 3C (4C set)

Ian Barbour SCD Archives

1- 8 1s cast 1 place, cross LH and cast round their 2nd corners to face 1st corners

9-16 1s dance reel of 3 on opposite sides (passing 1st corner RSh)

17-28 1s dance Fig of 8 Grand Chain – each change of hand is 2 bars:

1s change places RH with 1st corners on sides as 2nd corners cross diag RH, 1s cross diag LH as others change place LH on sides; continue this Fig back to place (Ladies in top place always cross diag with Man in 3rd place as others change place on sides)

29-32 1s set and cross RH

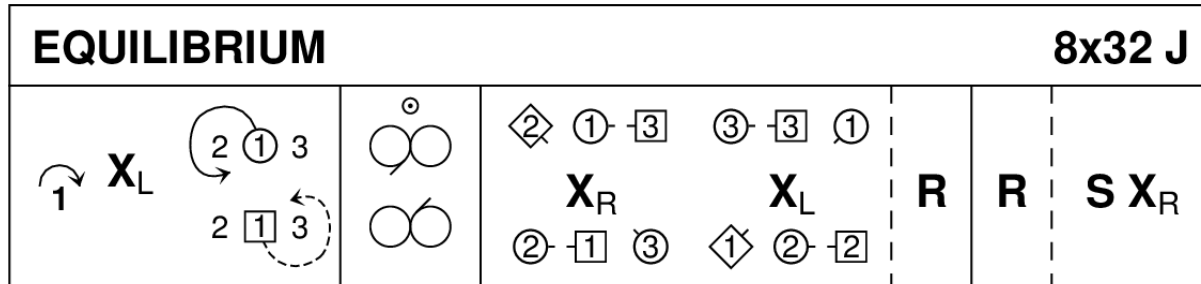

Ian Barbour, SDA

3C/4C longwise set.

THE BIRKS OF INVERMAY (S8x32) 3C (4C set)

Thomas Skillern RSCDS Book 16

1- 8 1M+2L turn 2H in 4 bars; 1L+2M turn 2H, on bar 8 1s+2s+3s dance in for...

9-16 1s+2s+3s Promenade

17-24 1s cross RH, cast to 2nd place, cross up between 2s and cast to 2nd place (2s step up on 23-24)

25-32 2s+1s+3s circle 6H round and back

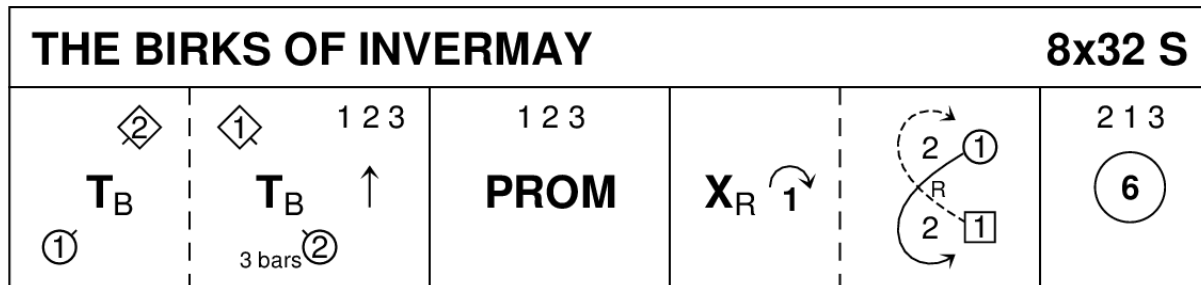

Skillern. 1776. RSCDS Book 16.2

3C/4C longwise set.

THE IRISH ROVER (R8x32) 3C (4C set)

James B. Cosh 22 SCDs

1- 8 1s dance down below 3s and cast up to 2nd place own sides (2C step up), 1L dances RH across with 2s while 1M dances RH across with 3s

9-16 1s dance ½ diagonal reel of 4 with 1st corners, ½ diagonal reel of 4 with 2nd corners and ½ turn LH in center to face 1st corners

17-24 1s dance reels of 3 across giving LSh to 1st corners and ending in 2nd place own sides (3)1(2)

25-32 1s dance Diag R&L (1M crossing down and 1L crossing up to start)

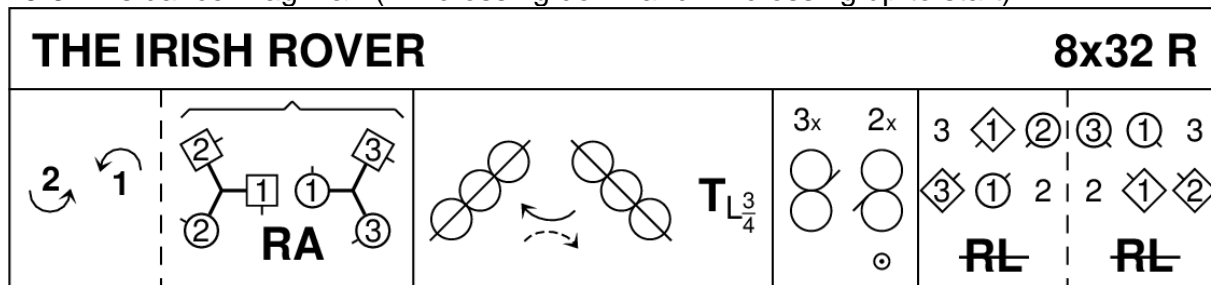

James B Cosh, 22 SCD & 1 other

3C/4C longwise set

November 2017 Portland Dance Cheat Sheets and Diagrams

LINTON PLOUGHMAN (J8x32) 2C (4C set)

RSCDS Book 5

- 1- 8 1s+2s circle 4H round and back
 9-16 1s+2s dance RH across and LH across
 17-24 1s lead down the middle and back
 25-32 1s+2s dance Poussette

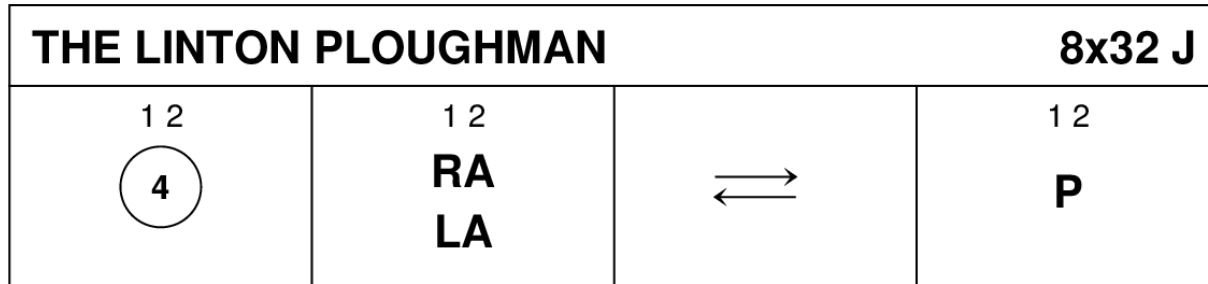

RSCDS Book 5.6

2C/4C longwise set.

CULLA BAY (S4x32) Sq. Set

Ann Dix RSCDS Book 41

- 1- 4 1s and 3s half turn and twirl opposite dancer RH, ending on opposite side
 5- 8 1s and 3s chase ¼ round set CW and dance in passing 2s/4s RSh then curve in to face 2s/4s as 2s and 4s repeat bars 1-4 and turn right about to face 1s/3s
 9-16 All dance parallel reels of 4 across set
 17-24 2s+1s also 4s+3s circle 4H once round to left, set and dance RH across ½ way
 25-32 2s+4s dance LH across once round, 2s and 4s dance out through sides passing 1s/3s RSh and chase round CW to next place

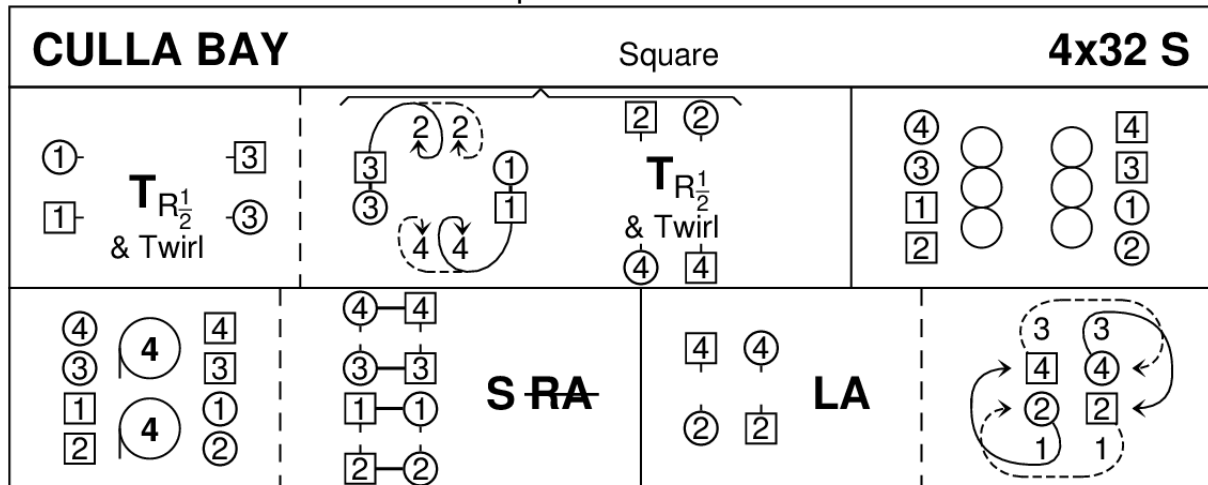

Ann Dix, 1992, Reel Friends, RSCDS Book 41.2

4C/4C square set.

THE DIAMOND QUARRIE (R8x32) 3C (4C set)

Elaine Brunken Moments in Time

- 1- 8 1s+2s dance Progressive Fig 8:
 1C cross RH, cast, cross up (no hands) through original positions, and cast off 1 place while 2C set, cross up (no hands) through 1st place on opp sides, cast off through 2nd place on opp sides, cross up (no hands) to top on own side and face out
 9-16 Mirror Reels 3 on sides - to start 2C dance out and down, 1C in and down, 3C out and up; 1C end facing 1st corners
 17-24 Hello-Goodbye setting
 25-32 Corner Pass and Turn

November 2017 Portland Dance Cheat Sheets and Diagrams

SUNSHINE AND SWEETIE'S JIG (J8x32) 3C (4C set)

Mervyn C Short RSCDS Book 48

- 1- 8 1s+2s set, dance ½ RH across, set, cross RH
 9-16 1s+1st corners turn RH, 1s finish facing 1st corners; 1s+1st corners dance ½ diagonal reel of 4; on bars 15-16 1M (from 3rd place) and 1L (from 1st place) cross up/down to 2nd place own sides
 17-24 1s+2nd corners repeat 9-16 but turning LH and passing LSh to start reel; on bars 23-24 1M (from 1st place), 1L (from 3rd place) cross down/up to 2nd place own sides (3)1(2)
 25-32 3s+1s+2s chase CCW halfway round; 1s set and cross RH

SUNSHINE AND SWEETIE'S JIG				8x32 J	
1 2 S RA	2x 1x S X_R	T_R			
T_L			3x 1 2x 	1x S X_R	

Mervyn C Short, 2011, RSCDS Book 48.7

3C/4C longwise set.

LADY SUSAN MONTGOMERY (S8x40) 3C (4C set)

David Young RSCDS Leaflet

- 1- 8 1M sets to 2L and casts to 2nd place (2M steps up), 1M+3L turn 2H
 9-16 1L sets to 2M and casts to 2nd place (2W steps up), 1L+3M turn 2H
 17-24 1s dance up between 2s, cast to 2nd place, dance down between 3s and cast up to 2nd place
 25-32 2s+1s+3s set and cross RH, set and cross back RH with 1s turning to face 2nd corners
 33-40 1s dance reels of 3 on sides giving RSh to 2nd corners, ending with 1s crossing to 2nd place own sides

LADY SUSAN MONTGOMERY					8x40 S		
							2 1 3 SX_R SX_R X_R

David Young, 1737, RSCDS Leaflet 33

3C/4C longwise set.

THE WHITE COCKADE (R8x32) 3C (4C set)

Preston RSCDS Book 5

- 1- 8 1s+2s+3s set and cross RH, set and cross back RH
 9-16 1s lead down the middle and up
 17-24 1s cast to 2nd place on own sides in 4 bars and circle 4H round to the left with 3s
 25-32 2s+1s dance R&L

THE WHITE COCKADE				8x32 R	
1 2 3 S X_R	1x 2x 3x S X_R	\rightleftharpoons			
			1 3 	2 1 RL	

Preston, 1797, RSCDS Book 5.11

3C/4C longwise set.