

THE GREENBELT JIG (J8x32) 3C (4C set)

- 1-8 1L+2L+3L dance round partners RSh & back to place (6 bars). All cross RH with partners
 9-16 1M+2M+3M repeat bars 1-8
 17-24 1s cast 2 places, dance up middle & cast to 2nd place (2s step up 17-18)
 25-32 2s+1s+3s Adv+Ret & all turn partners RH. 2 1 3

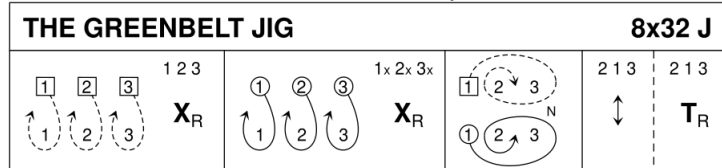

Elaine Brunken, 2010, Moments in Time

3C/4C longwise set.

UP IN THE AIR (S8x32) 3C (4C set)

- 1-8 1s cast down behind own lines, turning out cast back to top. Bar 8 all 3 couples dance in ready for ...
 9-16 1s+2s+3s Promenade, 1s cast & face 1st corners, 2s dance up to 1st place
 17-24 1s set to 1st corners, set to 2nd corners, pull back RSh turning into 2nd place opposite sides, 2s+1s+3s circle 6H round to left (4 bars – quick)
 25-32 2s+1s+3s Adv+Ret & turn 2H
 1s ending in 2nd place own sides. 2 1 3

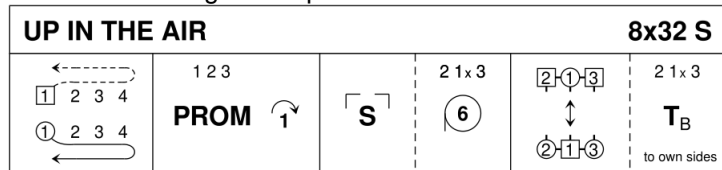

Boag, 1797, RSCDS Book 20.2

3C/4C longwise set.

NORMA'S GARDEN (R8x32) 3C (4C set)

- 1-8 1s dance down, cast up round 3s, dance up & cast to 2nd place own side (2s step up 7-8)
 9-16 1s dance Diag R&L (Man down, Lady up). (3) 1 (2)
 17-24 3s+1s+2s dance Set+Link for 3 couples twice. 2 (1) 3
 25-32 2s+1s+3s set, 1s turn 1.1/2 RH to 2nd place own side, 2s+1s+3s set

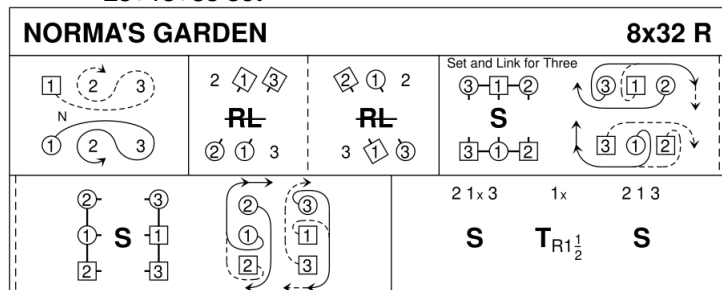

Lydia Hedge, 2010, Spark O' Water

3C/4C longwise set.

A TRIP TO THE DRAKENSBERG (J8x40) 3C (4C set)

- 1-8 1s set, cast 2 places & dance up to top (end with 2s stepping in below 1s)
 9-16 1s+2s dance Poussette (end with 1s facing 1st corners)
 17-24 1s dance 1/2 diagonal reel of 4 with 1st corners, pass LSh & dance 1/2 reel with 2nd corners (1s end 2nd place opposite side)
 25-32 3M+1M+2M petronella turn into centre & set while 3L+1L+2L set & petronella turn into centre, all turn partners RH (end in Allemande hold)
 33-40 3s+1s+2s dance Allemande

A TRIP TO THE DRAKENSBERG 8x40 J

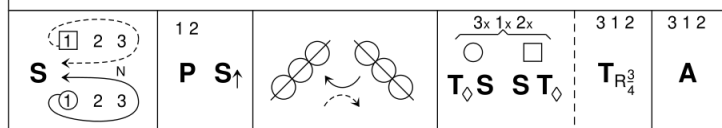

Barbara J Rendle-Braine, RSCDS Book 38.8

3C/4C longwise set.

HOPE LITTLE'S STRATHSPEY (S3x32) 3C set

- 1-8 1s+2s dance RH across back to places but 1L faces out & casts 2 places followed by partner, 1L crossing to 3rd place opposite side
 9-16 All dance Grand Chain
 17-24 1s set, turn 2H 1/2 way & dance up to top & cast to 3rd place own sides
 25-32 All circle 6H round & back

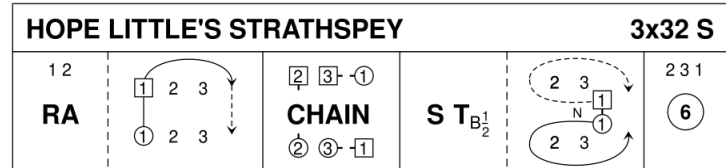

Roy Goldring, Graded and Social Dances 2

3C/3C longwise set.

THE MAPLE GROVE (R8x32) 2C (4C set)

- 1-8 1L+2M dance Back to Back; 1L+2M turn RH
 9-16 1M+2L dance Back to Back; 1M+2L turn RH
 17-24 1s dance Fig 8 found 2s
 25-32 1s followed by 2s dance down NH joined; 2s followed by 1s dance up to end 2s in 1st place, 1s in 2nd place

Note: May also be danced as reel

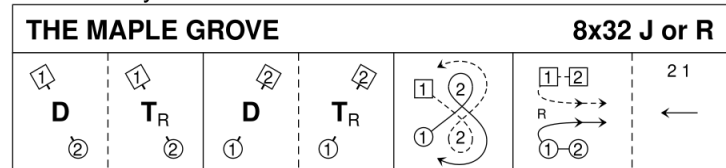

Liza Halpenny, 2008

2C/4C longwise set.

THE STARTLED RABBITS (J5x32) 5c Set

- 1-8 1s & 3s lead down for 3 steps, lead up to places & cast down 1 place
 9-16 2s+1s dance double Fig of 8 (1s cross up) while 4s+3s+5s dance reflection reels on own sides (3s in & down to start)
 17-24 2s+1s+4s dance reflection reels (1s in & down to start) while 3s+5s dance double Fig of 8 (3s cross down)
 25-32 1s & 3s cross RH & cast down 1 place, 1s & 3s dance 1/2 Fig of 8 round couple above them

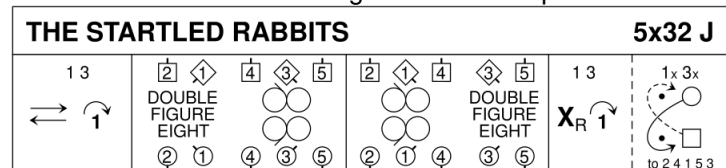

Derek Haynes, Carnforth 6

5C/5C longwise set.

THE EXPERT DANCER (S8x32) 3C (4C set)

- 1- 8 1s+2s dance the Bourrel:-
 `1M+2L set advancing, 3/4 turn 2H & twirl to end BtoB (Lady facing up & Man down) **while** partners chase anticlockwise 1/2 way
 `Set to partners & turn 2H to own sides having changed places
- 9-16 1s cross down & cast up behind 3s, dance up between 2s & cast to face 2nd corners
- 17-24 1s set to 2nd corners & turn 2H pivoting right about to face 1st corners, set to 1st corners & turn 2H pivoting right about to 1L facing up between 2s & 1M facing down between 3s
- 25-32 1s dance RSh reels of 3 across & cross LH to 2nd place own side

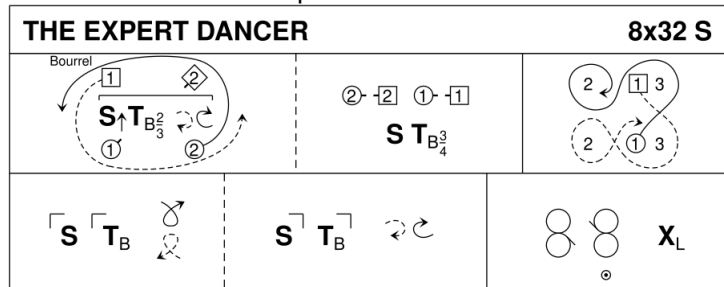

Bob Campbell, 1982, Farewell, My Fancy

3C/4C longwise set.

MARY ERSKINE (R8x32) 3C (4C set)

- 1- 8 1s+2s turn on sides 1.1/2 times (Men RH & Ladies LH), 1s cast down behind 3s, meet & dance up to 2nd place facing own sides ready for -
- 9-16 1s dance Double Triangles & end by turning right about to face each other (remaining in middle)
- 17-24 1s slip step down centre & back
- 25-32 1L dances LH across on Men's side **as** 1M dances RH across on Ladies side & dance 1/2 Fig of 8 round 2s

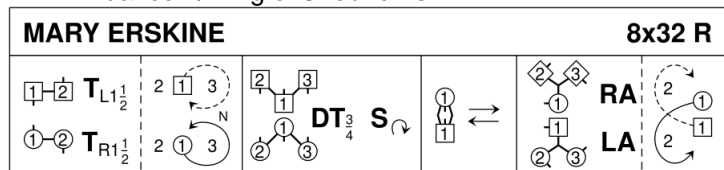

Roy Goldring, 1994, 15 Social Dances, RSCDS Graded Book 2.15

3C/4C longwise set.

KENDALL'S HORNPIPE (J8x32) 2C (4C set)

- 1- 8 1s+2s dance R&L
- 9-16 1s lead down for 3, up for 3, cross over & cast down to 2nd place
- 17-24 2s+1s dance Ladies' Chain
- 25-32 2s+1s Adv+Ret, 1s turn RH 1.1/2 times

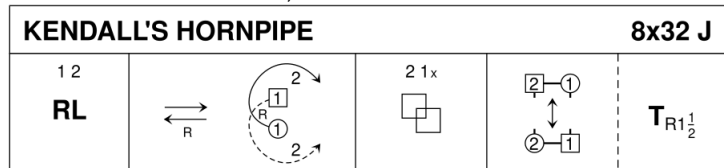

RSCDS Graded Book 1.22

2C/4C longwise set.

LAMMONBIE MILL (M-(S64+R64)) Sq.Set

- 1- 8 All circle 8H round & back
- 9-16 All set to partner & turn RH, set to corner & turn LH
- 17-32 All dance full Schiehallion Reel
- 33-40 All set & Petronella-in-tandem twice
- 41-48 1s+3s dance R&L
- 49-56 2s+4s dance R&L
- 57-64 All set & Petronella-in-tandem twice
- Repeat in reel time

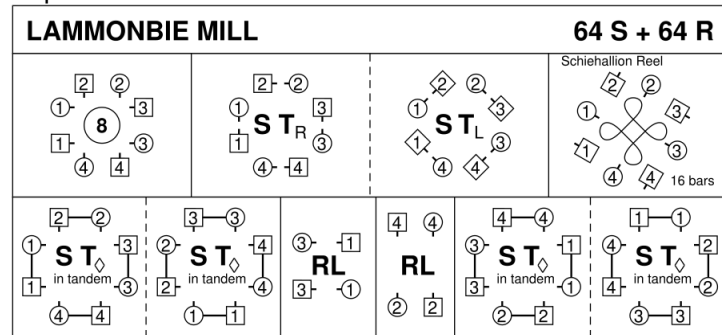

Harry Rhodes, 1993, Second Kirkbrae Collection

4C/4C square set.

BRIDGE OF NAIRN (S8x32) 3C (4C set)

- 1- 8 1s cast below 3s & lead up to top, cross & cast to meet partner facing 2L (2s step up 7-8)
- 9-16 1s set to 2L, 3M, 3L then 2M & turn to face 1st corners
- 17-24 1s turn 1st corner RH, partner LH, 2nd corner RH & partner LH ending in 2nd place opposite sides. 2 (1) 3
- 25-32 2s+1s+3s Adv+Ret & 1s turn with 2H 1.1/2 times. 2 1 3

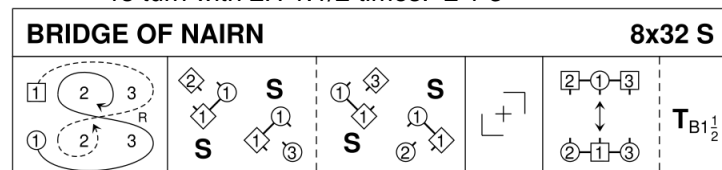

Robert Bremner, 1765, RSCDS Book 13.11

3C/4C longwise set.

CURRIE MOUNTAIN (R8x32) 3C (4C set)

- 1- 8 1s cross RH & cast 1 place, dance 1/2 Fig of 8 round 2s
- 9-16 1s turn 3s with nearer hands (1s dancing between 3s) & turn 2s with other hand
- 17-24 1s+3s dance RH across, 1s+2s dance LH across
- 25-32 2s+1s+3s dance reels of 3 on sides (1s giving RSh to 3s to start)

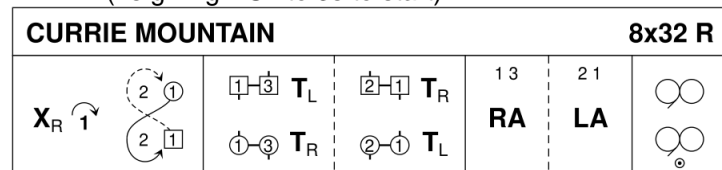

Mary Pugh, 1983, New Brunswick Collection

3C/4C longwise set.

RSCDS SW WA State Branch Anniversary Dance April 26, 2025

EARLY SPRING (S3x32) 3C set

- 1- 8 Men dance RSh round partners; all 3 couples turn partner RH
- 9-16 Ladies dance LSh round partners; all 3 couples turn LH, remaining in middle facing up ready for ...
- 17-24 1s+2s+3s dance Allemande
- 25-32 3s+2s dance Tourbillon
- 25-28 3s & 2s 1/2 turn ptrns 2H, 3M & 2L lead ptrns by nearer hand 1 place cl'wise to end 3s on Ladies side & 2s Men's side, 3s set to 2s
- 29-32 3s & 2s 1/2 turn ptrns 2H & lead ptrns on 1 place clockwise & 2s+3s cross RH to own sides

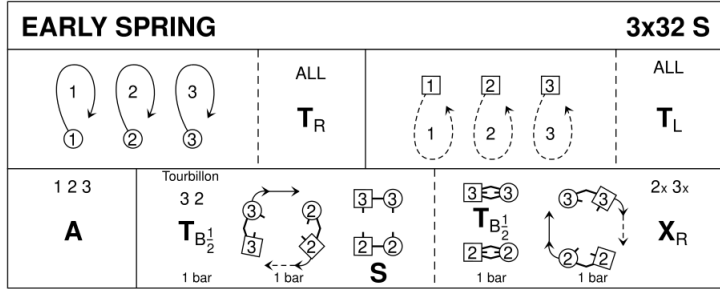

Isabel Neves, World Wide Weavings

3C/3C longwise set.

GRANVILLE MARKET (J8x32) 3C (4C set)

- 1- 8 1s+2s dance RH across & LH back
- 9-16 1s cross RH & cast 1 place, 1s dance 1/2 Fig of 8 around 2s & end facing 1st corner
- 17-24 1s turn corners RH & pass RSh to face 2nd corners, 1s turn 2nd corners RH & pass RSh to end 2nd place own sides
- 25-32 2s+1s+3s circle 6H round & back

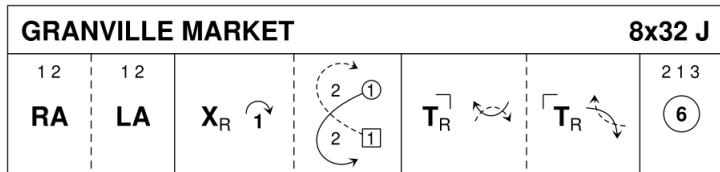

Elinor M Vandegriff, RSCDS Graded Book 2.18

3C/4C longwise set.

SYMBOLS USED IN KEITH ROSE DIAGRAMS

Top of Set is on Left ... 2, 4 & 8 bar phrase boundaries 1 Ladies } Numbered & facing as shown 2 Men } Inactive if grey 3 Inactive Left hand dancer in trio Ladies' Path Men's Path	2 1 x 3 Dancing Couples (x = Crossed Over) 1 2 3, 4th Corners Simultaneous Movements Sequence Leading man (in reels) Half Figure	↑ ↓ Advance Retire ⇕ Advance & Retire ⇔ Down and Up ↻ Cast Off, Up (1, 2 places) ↻ Lead Down, Up ↻ Long cast (4 bars)
One Hand Joined Both Hands Joined Promenade Hold Allemande Hold Make Arch	4 Circle, 4 Hands Round & Back Circle Left, Right Chase Clockwise, Anti-clockwise Reels of 3, 4 (1C entry shown)	Ladies' Chain Men's Chain Turn 1st Corner, Partner, 2nd Corner, Partner Clap Petronella
A Allemande B Balance in Line D Do-si-do (Back to Back) DT Double Triangles HS Highland Schottische LA RA Left, Right Hands Across	P Poussette PROM Promenade R Repeat RL Rights & Lefts S Set T Turn X Cross	Suffixes: B Both Hands L Left Hand R Right Hand N Nearer Hand X Crossed Hands ◇ Petronella ↑ Advancing ↻ Rotating

Keith Rose, 2022